



**Allowable Ampacities of Insulated Conductors**  
**COPPER**

	60°C (140°F)	75°C (167°F)	90°C (194°F)
AWG	TYPES TW, UF	TYPES RHW, THHW, THW, THWN, XHHW, USE, ZW	TYPES TBS,SA, SIS, FEP, FEPB, MI, RHH, RHW-2, THHN, THHW, THW-2, THWN-2 USE-2, XHH XHHW, XHHW-2 ZW-2
kcmil			
18	.....	.....	14
16	.....	.....	18
14**	15	20	25
12**	20	25	30
10**	30	35	40
8	40	50	55
6	55	65	75
4	70	85	95
3	85	100	115
2	95	115	130
1	110	130	145
1/0	125	150	170
2/0	145	175	195
3/0	165	200	225
4/0	195	230	260
250	215	255	290
300	240	285	320
350	260	310	350
400	280	335	380
500	320	380	430
600	350	420	475
700	385	460	520
750	400	475	535
800	410	490	555
900	435	520	585
1000	455	545	615
1250	495	590	665
1500	525	625	705
1750	545	650	735
2000	555	665	750



**Allowable Ampacities of Insulated Conductors  
ALUMINUM or Copper Clad Aluminum**

	60°C (140°F)	75°C (167°F)	90°C (194°F)
AWG	TYPES TW, UF	TYPES RHW, THHW, THW, THWN, XHHW, USE	TYPES TBS, SA, SIS, THN, THHW, THW-2, THWN-2, RHH, RHW-2, USE-2, XHH, XHHW, XHHW-2, ZW-2
kcmil			
.....	.....	.....	.....
.....	.....	.....	.....
.....	.....	.....	.....
12**	15	20	25
10**	25	30	35
8	35	40	45
6	40	50	55
4	55	65	75
3	65	75	85
2	75	90	100
1	85	100	115
1/0	100	120	135
2/0	115	135	150
3/0	130	155	175
4/0	150	180	205
250	170	205	230
300	195	230	260
350	210	250	280
400	225	270	305
500	260	310	350
600	285	340	385
700	315	375	425
750	320	385	435
800	330	395	445
900	355	425	480
1000	375	445	500
1250	405	485	545
1500	435	520	585
1750	455	545	615
2000	470	560	630



### ADJUSTMENT FACTORS

When there are more than three current-carrying conductors in a raceway or cable, the ampacity of each conductor must be reduced as indicated in Table 310.15(B)(3)(a) to compensate for heating effects and reduced heat dissipation due to reduced ventilation of individual conductors.

**Table 310.15(B)(3)(a). Adjustment Factors.**

**(a) More than Three Conductors in a Raceway or Cable.** Where the number of conductors in a raceway or cable exceeds three, the ampacities shall be reduced as shown in the following table:

Number of Conductors	Adjustment Factor
4 through 6	80%
7 through 9	70%
10 through 20	50%
21 through 30	45%
31 through 40	40%
41 and above	35%

Example: A conduit contains six #8 TW current carrying conductors. The normal ampacity is 40 amps x 80% adjustment factor = 32 amps. The maximum current that can be passed through the #8 TW conductor without subjecting it to insulation damage is 32 amps.

It is wrong to think that by using a larger size conduit than required would satisfy the adjustment factor required for the reduction of ampacity. The larger conduit would have more volume area, but it's like heating a rock, it may take a little longer but it will still reach the same temperature.



## BOX FILL EXAMPLE

BOX FILL																	
	<table><thead><tr><th colspan="2">Conductor Cubic Inch</th></tr></thead><tbody><tr><td>#18 = 1.5</td><td>cubic inch</td></tr><tr><td>#16 = 1.75</td><td>cubic inch</td></tr><tr><td>#14 = 2</td><td>cubic inch</td></tr><tr><td>#12 = 2.25</td><td>cubic inch</td></tr><tr><td>#10 = 2.5</td><td>cubic inch</td></tr><tr><td>#8 = 3</td><td>cubic inch</td></tr><tr><td>#6 = 5</td><td>cubic inch</td></tr></tbody></table>	Conductor Cubic Inch		#18 = 1.5	cubic inch	#16 = 1.75	cubic inch	#14 = 2	cubic inch	#12 = 2.25	cubic inch	#10 = 2.5	cubic inch	#8 = 3	cubic inch	#6 = 5	cubic inch
Conductor Cubic Inch																	
#18 = 1.5	cubic inch																
#16 = 1.75	cubic inch																
#14 = 2	cubic inch																
#12 = 2.25	cubic inch																
#10 = 2.5	cubic inch																
#8 = 3	cubic inch																
#6 = 5	cubic inch																

Table 314.16(B) is a very useful table for everyday box sizing. The electrician should memorize, #14 conductor = 2 cubic inches, and a #12 conductor = 2.25 cubic inches. These two conductors are the most often used in calculating the correct box size using devices. Example, if the electrician is installing #14 conductors, count the conductors, clamps, devices, and multiply the total conductors times 2 cubic inches and this will determine the minimum cubic inch capacity required. Boxes not shown in Table 314.16(A) are required to have the cubic inch capacity marked (314.16(A2)).

(continued)

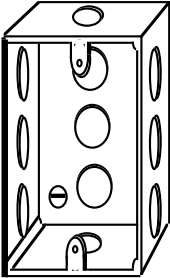

Example: Table 314.16(A) shows a 4 11/16" x 1 1/4" square box will hold 11 - #12 conductors. If this box contained three #12-2 with ground nonmetallic sheathed cables, cable clamps, and two duplex receptacles (two straps).

3 - #12 black conductors = 3 conductors  
 3 - #12 white conductors = 3 conductors  
 3 - #12 bare conductors = 1 conductor  
 3 - cable clamps = 1 conductor  
 2 - duplex receptacles = 4 conductors  
12 conductors

12 - #12 conductors x 2.25 cubic inches = 27 cubic inch box required, a 4 11/16" x 1 1/4" square box at 25.5 cubic inches would be a **violation**.

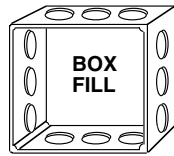

**Fixture Stud (one or more)** Count one wire



**Cable Clamp (one or more)** Count one wire



**Hickey (one or more)** Count one wire



**Switch** Count two wires



**Receptacle** Count two wires



 **Black or white wire** Count one wire for each wire

 **Grounding wire (one or more)** Count one wire for all



**Maximum number of wires in Metal Boxes**

Box Dimension, Inches Trade Size or Type	Min. Cu. In. Cap.	Maximum number of wires						
		#18	#16	#14	#12	#10	#8	#6
4 x 1-1/4 Round or Octagonal	12.5	8	7	6	5	5	5	2
4 x 1-1/2 Round or Octagonal	15.5	10	8	7	6	6	5	3
4 x 2-1/8 Round or Octagonal	21.5	14	12	10	9	8	7	4
4 x 1-1/4 Square	18.0	12	10	9	8	7	6	3
4 x 1-1/2 Square	21.0	14	12	10	9	8	7	4
4 x 2-1/8 Square	30.3	20	17	15	13	12	10	6
4-11/16 x 1-1/4 Square	25.5	17	14	12	11	10	8	5
4-11/16 x 1-1/2 Square	29.5	19	16	14	13	11	9	5
4-11/16 x 2-1/8 Square	42.0	28	24	21	18	16	14	8
3 x 2 x 1-1/2 Device	7.5	5	4	3	3	3	2	1
3 x 2 x 2 Device	10.0	6	5	5	4	4	3	2
3 x 2 x 2-1/4 Device	10.5	7	6	5	4	4	3	2
3 x 2 x 2-1/2 Device	12.5	8	7	6	5	5	4	2
3 x 2 x 2-3/4 Device	14.0	9	8	7	6	5	4	2
3 x 2 x 3-1/2 Device	18.0	12	10	9	8	7	6	3
4 x 2-1/8 x 1-1/2 Device	10.3	6	5	5	4	4	3	2
4 x 2-1/8 x 1-7/8 Device	13.0	8	7	6	5	5	4	2
4 x 2-1/8 x 2-1/8 Device	14.5	9	8	7	6	5	4	2
3-3/4 x 2 x 2-1/2 Masonry Box / Gang	14.0	9	8	7	6	5	4	2
3-3/4 x 2 x 3-1/2 Masonry Box / Gang	21.0	14	12	10	9	8	7	4
FS — Minimum Internal Depth 1-3/4 Single Cover/Gang	13.5	9	7	6	6	5	4	2
FD — Minimum Internal Depth 2-3/8 Single Cover/Gang	18.0	12	10	9	8	7	6	3
FS — Minimum Internal Depth 1-3/4 Multiple Cover/Gang	18.0	12	10	9	8	7	6	3
FD — Minimum Internal Depth 2-3/8 Multiple Cover/Gang	24.0	16	13	12	10	9	8	4

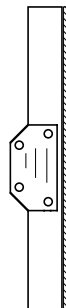

**IF THE WALL SURFACE IS MADE OF A NONCOMBUSTIBLE MATERIAL THE BOX MAY BE MOUNTED NO MORE THAN 1/4" BACK FROM THE SURFACE**



**IF THE WALL SURFACE IS MADE OF A COMBUSTIBLE MATERIAL THE BOX MUST BE MOUNTED FLUSH WITH THE SURFACE**



## OFFSET BEND CHART

DEGREE OF BEND	→ 22 1/2°		→ 30°		→ 45°		→ 60°	
OFFSET	BETWEEN BENDS	SHRINK AMOUNT	BETWEEN BENDS	SHRINK AMOUNT	BETWEEN BENDS	SHRINK AMOUNT	BETWEEN BENDS	SHRINK AMOUNT
2"	5 1/4"	3/8"						
2 1/2"	6 1/2"	1/2"						
3"	7 3/4"	9/16"	6"	3/4"				
3 1/2"	9 1/8"	1 1/16"	7"	7/8"				
4"	10 1/2"	3/4"	8"	1"				
4 1/2"	11 3/4"	7/8"	9"	1 1/8"				
5"	13"	15/16"	10"	1 1/4"	7"	1 7/8"		
5 1/2"	14 3/8"	1"	11"	1 3/8"	7 3/4"	2"		
6"	15 1/2"	1 1/8"	12"	1 1/2"	8 1/2"	2 1/4"	7 1/4"	3"
6 1/2"	16 15/16"	1 1/4"	13"	1 5/8"	9 1/8"	2 7/16"	7 13/16"	3 1/4"
7"	18 1/4"	1 5/16"	14"	1 3/4"	9 3/4"	2 5/8"	8 3/8"	3 1/2"
7 1/2"	19 1/2"	1 7/16"	15"	1 7/8"	10 1/2"	2 13/16"	9"	3 3/4"
8"	20 3/4"	1 1/2"	16"	2"	11 1/4"	3"	9 5/8"	4"
8 1/2"	22 1/8"	1 5/8"	17"	2 1/8"	11 15/16"	3 3/16"	10 1/4"	4 1/4"
9"	23 1/2"	1 3/4"	18"	2 1/4"	12 1/2"	3 3/8"	10 7/8"	4 1/2"
9 1/2"	24 3/4"	1 13/16"	19"	2 3/8"	13 3/8"	3 9/16"	11 7/16"	4 3/4"
10"	26"	1 7/8"	20"	2 1/2"	14"	3 3/4"	12"	5"
10 1/2"	27 3/8"	2"	21"	2 5/8"	14 3/4"	3 15/16"	12 5/8"	5 1/4"
11"	28 5/8"	2 1/16"	22"	2 3/4"	15 7/16"	4 1/8"	13 1/4"	5 1/2"
11 1/2"	29 15/16"	2 3/16"	23"	2 7/8"	16 1/8"	4 5/16"	13 7/8"	5 3/4"
12"	31 1/4"	2 1/4"	24"	3"	16 13/16"	4 1/2"	14 7/16"	6"
15"	39"	2 13/16"	30"	3 3/4"	21"	5 5/8"	18"	7 1/2"
24"	62 7/16"	4 1/2"	48"	6"	33 5/8"	9"	28 13/16"	12"

•The dimensions in the chart above were calculated using the offset formula below. •Always start bends at *arrow* on bender. © Tom Henry 2007

OFFSET FORMULA		
Distance between bends = Depth of offset x Multiplier		
Angle	Multiplier of Offset Depth	Shrinkage Per Inch of Rise
10° x 10°	6	1/16" per inch
22 1/2° x 22 1/2°	2.6	3/16" per inch
30° x 30°	2	1/4" per inch
45° x 45°	1.4	3/8" per inch
60° x 60°	1.2	1/2" per inch

For offsets 5 inches or more use 45° or 60° bends.

For offsets of 3 or 4 inches use 30° bends.

For offsets of 2 inches in depth use 22 1/2° bends.

For small offsets of 1 inch or less use 10° bends.



Maximum Number Wires EMT (Thinwall)							
Insulation	Wire size	EMT size $\varnothing$ _____					
		1/2"	3/4"	1"	1 1/4"	1 1/2"	2"
TW	#14	8	15	25	43	58	96
	#12	6	11	19	33	45	74
	#10	5	8	14	24	33	55
	#8	2	5	8	13	18	30
THW	#14	6	10	16	28	39	64
THHW	#12	4	8	13	23	31	51
	#10	3	6	10	18	24	40
	#8	1	4	6	10	14	24
	#6	1	3	4	8	11	18
	#4	1	1	3	6	8	13
	#3	1	1	3	5	7	12
	#2	1	1	2	4	6	10
	#1	1	1	1	3	4	7
	#1/0	0	1	1	2	3	6
	#2/0	0	1	1	1	3	5
	#3/0	0	1	1	1	2	4
	#4/0	0	0	1	1	1	3
	THHN	#14	12	22	35	61	84
THWN	#12	9	16	26	45	61	101
THWN-2	#10	5	10	16	28	38	63
	#8	3	6	9	16	22	36
	#6	2	4	7	12	16	26
	#4	1	2	4	7	10	16
	#3	1	1	3	6	8	13
	#2	1	1	3	5	7	11
	#1	1	1	1	4	5	8
	#1/0	1	1	1	3	4	7
	#2/0	0	1	1	2	3	6
	#3/0	0	1	1	1	3	5
	#4/0	0	1	1	1	2	4
	#250	0	0	1	1	1	3





### VOLTAGE DROP

**POWER LOSS = VD x I**

Voltage Drop....  $VD = 2 \times \frac{K \times D \times I}{CM}$  (or)  $VD = I \times R$

Wire Size .....  $CM = 2 \times \frac{K \times D \times I}{VD \text{ per}}$

Distance .....  $D = \frac{CM \times VD \text{ per}}{2 \times K \times I}$

Load .....  $I = \frac{CM \times VD \text{ per}}{2 \times K \times D}$

- The "2" in the formulas is for 1  $\phi$ .
- For 3  $\phi$  change the "2" to 1.732.
- "k" is the resistance of a cm foot  $K = \frac{R \times CM}{1000}$
- When using the formula to find "WIRE SIZE" use the approximate (K) of 12.9 for copper and 21.2 for alum.
- "D" is the distance ONE WAY in a circuit.
- "I" is the load in amperes.
- "CM" is the wire size in circular mils, found in Table 8.
- "VD per" is the percentage of the applied voltage.  
3% VD per for a branch circuit and 5% total system.

Example: A 120v branch circuit is permitted to drop  
 $3\% \times 120v = 3.6$  volts. A 240v branch circuit  $3\% \times 240v = 7.2$  volts. A 208v branch circuit  $3\% \times 208v = 6.24$  VD permitted.  
 Total system:  $240v \times 5\% = 12$  volts permitted.



**EXACT K @ 75°C**

DESIGNED BY TOM HENRY  
CODE ELECTRICAL CLASSES

AWG	Area Circular Mils	Copper Un-coated Resistance	Copper Un-coated EXACT K	Copper Coated Resistance	Copper Coated EXACT K	Aluminum Resistance	Aluminum EXACT K
#14 SOLID	4110	3.07	12.6177	3.19	13.1109	5.06	20.7966
#14 STRANDED	4110	3.14	12.9054	3.26	13.3986	5.17	21.2487
#12 SOLID	6530	1.93	12.6029	2.01	13.1253	3.18	20.7654
#12 STRANDED	6530	1.98	12.9294	2.05	13.3865	3.25	21.2225
#10 SOLID	10 380	1.21	12.5598	1.26	13.078	2.00	20.76
#10 STRANDED	10 380	1.24	12.8712	1.29	13.3902	2.04	21.1752
#8 SOLID	16 510	0.764	12.61364	0.786	12.97686	1.26	20.8026
#8 STRANDED	16 510	0.778	12.84478	0.809	13.35659	1.28	21.1328
#6	26 240	0.491	12.88384	0.510	13.3824	0.808	21.20192
#4	41 740	0.308	12.85592	0.321	13.39854	0.508	21.20392
#3	52 620	0.245	12.8919	0.254	13.36548	0.403	21.20586
#2	66 360	0.194	12.87384	0.201	13.33836	0.319	21.16884
#1	83 690	0.154	12.88826	0.160	13.3904	0.253	21.17357
#1/0	105 600	0.122	12.8832	0.127	13.4112	0.201	21.2256
#2/0	133 100	0.0967	12.87077	0.101	13.443	0.159	21.1629
#3/0	167 800	0.0766	12.85348	0.0797	13.37366	0.126	21.1428
#4/0	211 600	0.0608	12.86528	0.0626	13.24616	0.100	21.16
250 kcmil	250 000	0.0515	12.875	0.0535	13.375	0.0847	21.175
500 kcmil	500 000	0.0258	12.9	0.0265	13.25	0.0424	21.2
1000 kcmil	1 000 000	0.0129	12.9	0.0132	13.2	0.0212	21.2

© 1986 Tom Henry

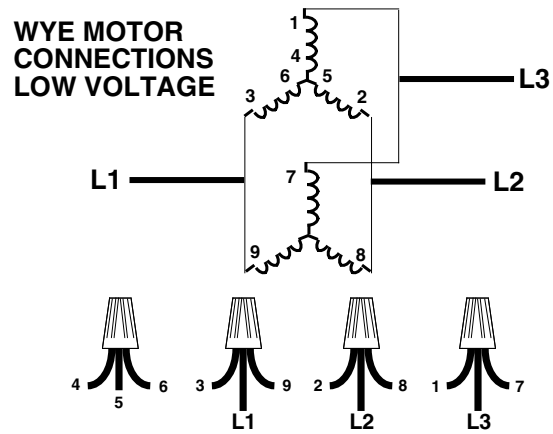
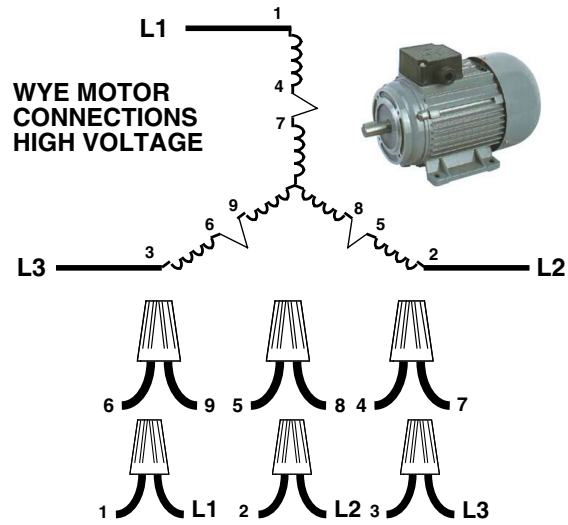

**DELTA MOTOR CONNECTIONS HIGH VOLTAGE**

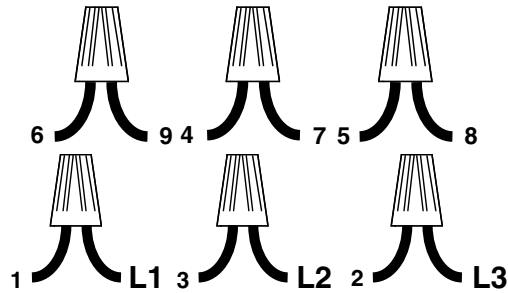
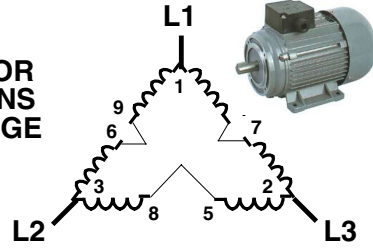

**DELTA MOTOR CONNECTIONS LOW VOLTAGE**

